

Installation Note

Agilent Technologies ESA-E Series Spectrum Analyzers TV Trigger and Picture-On-Screen (Option B7B)



Agilent Technologies

Part Number E4401-90451 Supersedes E4401-90440

Printed in USA April 2003



E4401-90451

Notice.

The information contained in this document is subject to change without notice.

Agilent Technologies makes no warranty of any kind with regard to this material, including but not limited to, the implied warranties of merchantability and fitness for a particular purpose. Agilent Technologies shall not be liable for errors contained herein or for incidental or consequential damages in connection with the furnishing, performance, or use of this material.

Microsoft® is a U.S. registered trademark of Microsoft Corp.

TV Trigger and Picture-On-Screen (Option B7B)

Products Affected:	ESA E4401B ESA E4402B ESA E4404B ESA E4405B ESA E4407B
Serial Numbers:	US00000000/US99999999 MY00000000/MY99999999
Options:	B7B
To Be Performed By:	(X) Agilent Service Center (X) Personnel Qualified by Agilent (X) Customer
Estimated Installation Time:	2 Hours

Introduction

This kit contains the parts and instructions to install Option B7B in Agilent ESA models listed above that already have Option BAA (FM Demodulation) installed.

NOTE Option BAA (FM Demodulation) must be installed in your spectrum analyzer before this Option B7B retrofit kit can be installed. To order option BAA, contact your nearest Agilent service or sales office for assistance.

Installation Kit Parts List

Item	Description	Part Number
1	Ribbon Cable	E4401-60187
2	TV Trigger and Picture-On-Screen Installation Note	this note
3	License Key Certificate	5964-5136 ^a
4	Letter	5964-5139 ^a
5	Option BAA ROM Kit	E4401-60338

a. This part cannot be ordered. The part number is given only to identify the item in this kit.

Tools Required

- T-8 TORX screwdriver
- T-10 TORX screwdriver
- T-15 TORX screwdriver

Torque Settings

To avoid potential RFI leakage, tighten screws to the following torque limits:

Item	Torque
3-mm, T-8 TORX screws	101 N-cm (9 in-lb)
3.5-mm, T-10 TORX screws	157 N-cm (14 in-lb)
4-mm, T-15 TORX screws	236 N-cm (21 in-lb)
Pozidrive Screws	157 N-cm (14 in-lb)

Equipment Required (for functional testing)

- TV RF source (such as a CATV signal or VCR)

Procedure

Check for Option BAA Installation

1. Turn on the spectrum analyzer and press **System, More, Show System** and note whether or not your instrument has Option BAA (FM Demodulation) installed. If Option BAA is not installed, stop this procedure now and order this option by contacting your nearest Agilent service or sales office. If Option BAA is installed or you are ready to install it, continue with this procedure.

Remove Outer Cover

WARNING Before you disassemble the instrument, turn the power switch OFF and unplug the instrument. Failure to unplug the instrument can result in personal injury.

CAUTION Electrostatic discharge (ESD) can damage or destroy electronic components. All work on electronic assemblies should be performed at a static-safe workstation. Refer to the documentation that pertains to your instrument for information about static-safe workstations and ordering static-safe accessories.

1. See [Figure 1](#). Disconnect the spectrum analyzer from ac power (1).

Figure 1. Cover and Rear Frame Removal

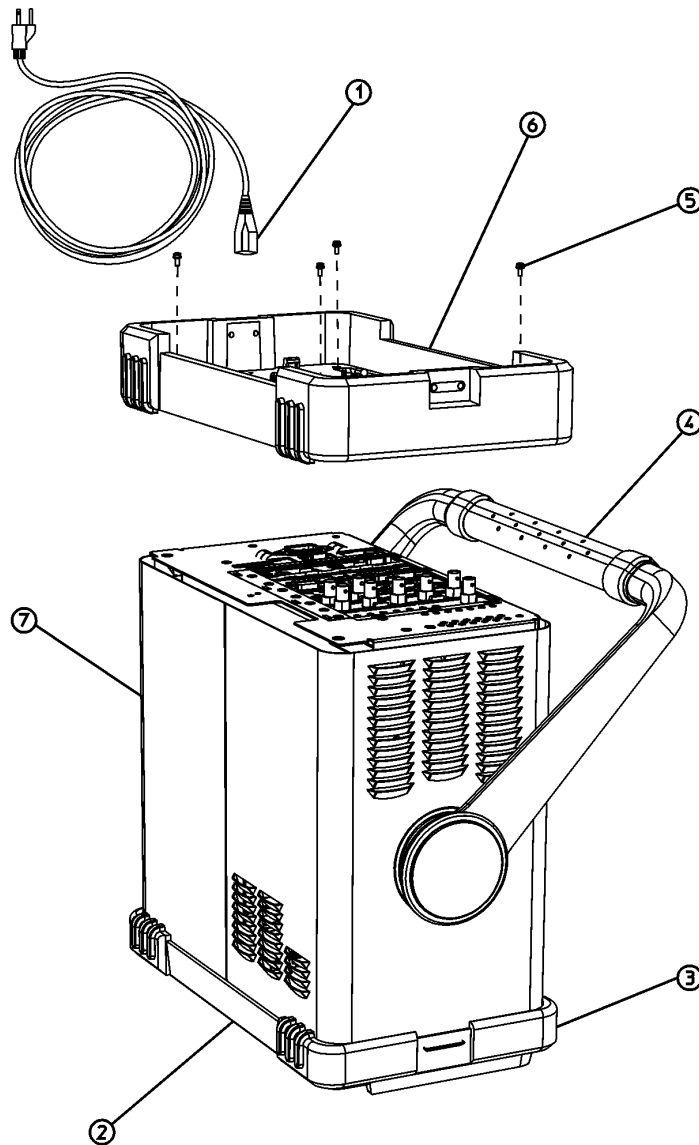

dl71b

2. Remove any adapters or cables (2) connected to the front panel.
3. Carefully place the analyzer on the work surface with the front frame (3) facing down.
4. Position the handle (4) as shown.
5. Remove the four screws (5) that hold the rear frame and outer case in place.
6. Remove the rear frame (6).
7. Pull the outer cover (7) off towards the rear of the instrument.

Remove Inner Shield

1. Lay the instrument flat as shown in [Figure 2](#).

Figure 2. Inner Shield Removal

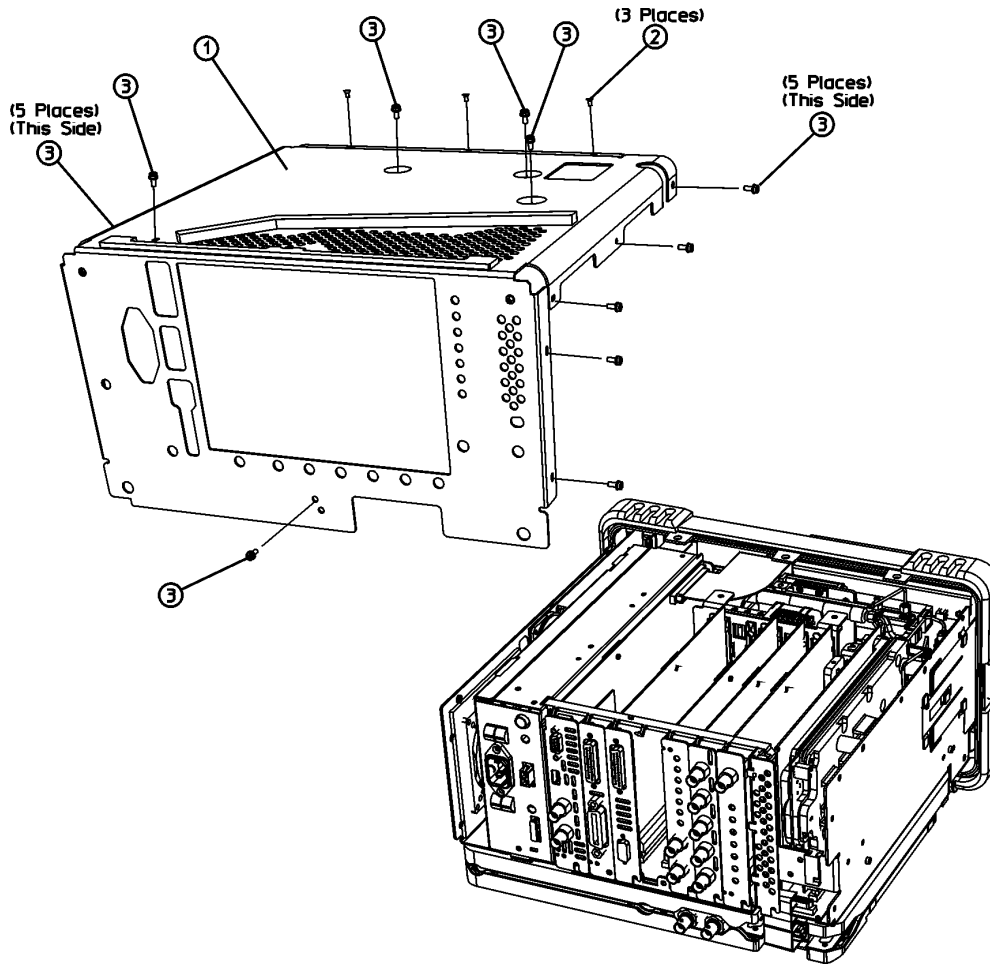

d172b

2. Remove the 15 screws (2) and (3) attaching the inner shield to the chassis. Note that the number of screws attaching the inner shield may vary with option mixes.
3. Remove the inner shield (1) from the chassis.

Remove the Vibration Support Bar

CAUTION The vibration support bar can easily be broken if it is forced. Remove it with care.

1. See [Figure 3](#). Loosen, but do not remove, all 9 of the screws (1) securing the boards and blank plates at the rear of the chassis.
2. On the vibration support bar, press in the locking tabs (2) and rotate the bar (3) upward. Remove the bar by sliding it out of the holes in each of the assemblies and lifting it up.

Figure 3. Instrument Rear View

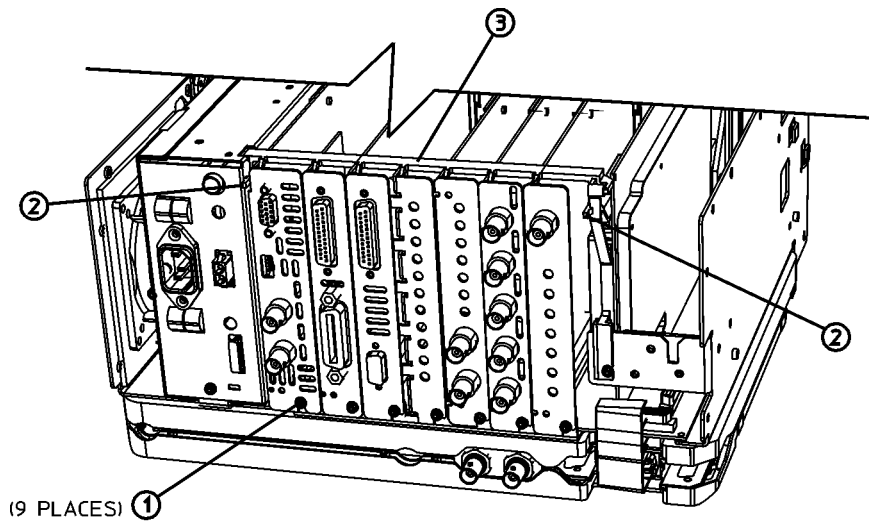

sl754b

Install Option BAA if Not Installed

1. If Option BAA (FM Demodulation) is not installed in your instrument, install that option now. Before re-installing the instrument covers, install the front panel interface ribbon cable (included with this kit) as described in the next procedure.

Check Option BAA - LCD Compatibility

1. The ESA-E Series Spectrum Analyzers have used different LCDs over the life of the product. Because of this you must check the version of the LCD that is installed in the instrument that is being upgraded to make sure that the Option B7B TV Picture on-screen functionality will work properly. A BAA ROM Kit is included with this upgrade that provides all of the instructions and required parts needed for this.
2. Install the Option BAA ROM Kit.

Install the Front Panel Interface Ribbon Cable

1. See [Figure 4](#). Connect the ribbon cable to P2 (1) on the front panel keyboard interface board.

NOTE Be sure to use the outermost connectors on the ribbon cable, as the inner connectors are grounds only. These grounds were designed to suppress EMI.

NOTE See [Figure 3](#). The ribbon cable attaches to the Option BAA board, which may be located in instrument slots 3 or 4. This cable is long enough to reach the ribbon connector when the board is in either slot.

Figure 4. Installing the Front Panel Interface Ribbon Cable

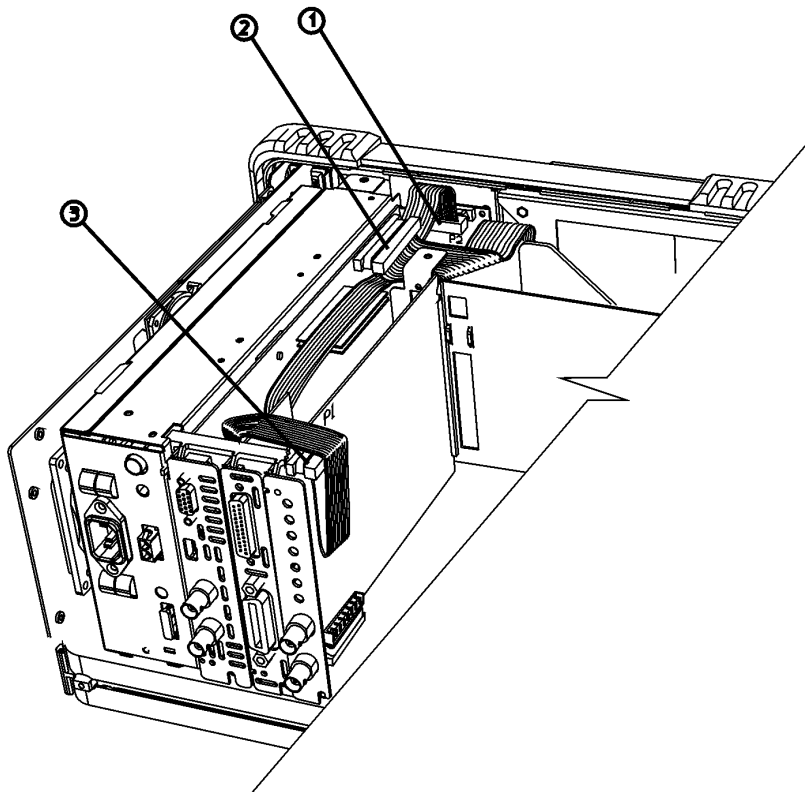

j171b

2. Locate and temporarily disconnect the 80-pin CPU ribbon cable (2) from the CPU board.
3. Route the cable as shown in the figure and connect the other end to P1 (3) on the FM Demodulator board. Leave enough room to re-attach the vibration support bar.
4. Re-connect the 80-pin CPU ribbon cable to the CPU board.

Replace the Vibration Support Bar

CAUTION The vibration support bar can easily be broken if it is forced. Install it with care.

See [Figure 5](#). Replace the vibration support bar (1) as follows:

1. Position the vibration support bar as shown and insert the hook (2) into the support arm that holds the instrument IF assembly. Be careful not to pinch the ribbon cable just installed.
2. Engage each hook (3) of the other assemblies or blanks in turn.
3. As you position each of the assemblies or blanks, rotate (4) the support bar to lock each one in place.

Figure 5. Installing the Vibration Support Bar

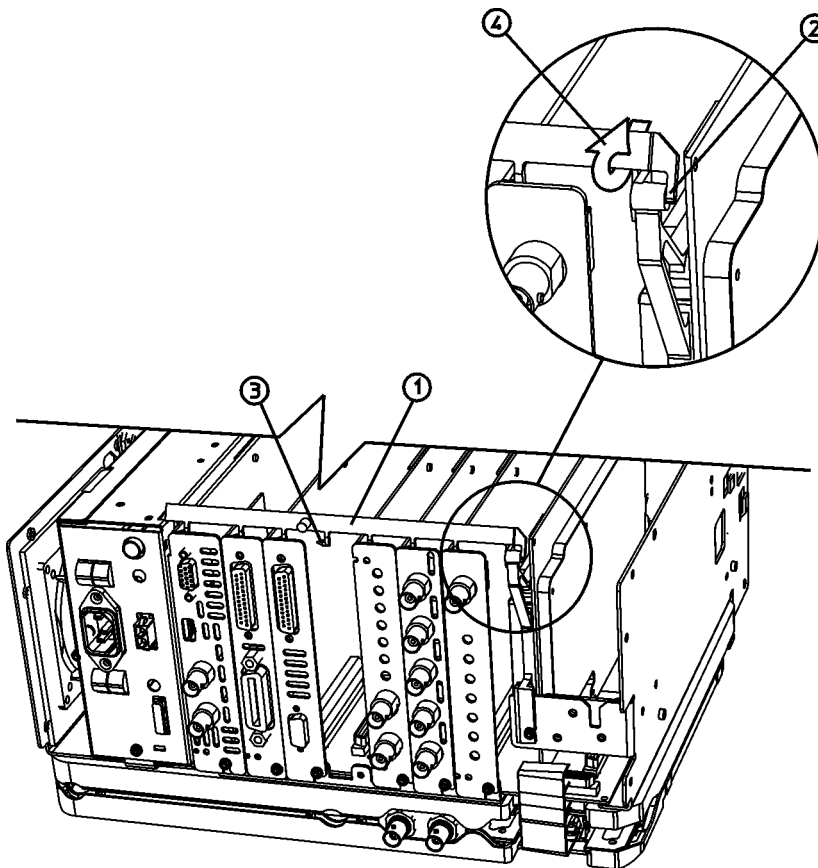

sl753b

4. See [Figure 6](#). Make sure that the tab (1) is positioned in the slot of the power supply chassis and the vibration bar is fully seated and locked (2) into position.

Figure 6. Seating the Vibration Support Bar

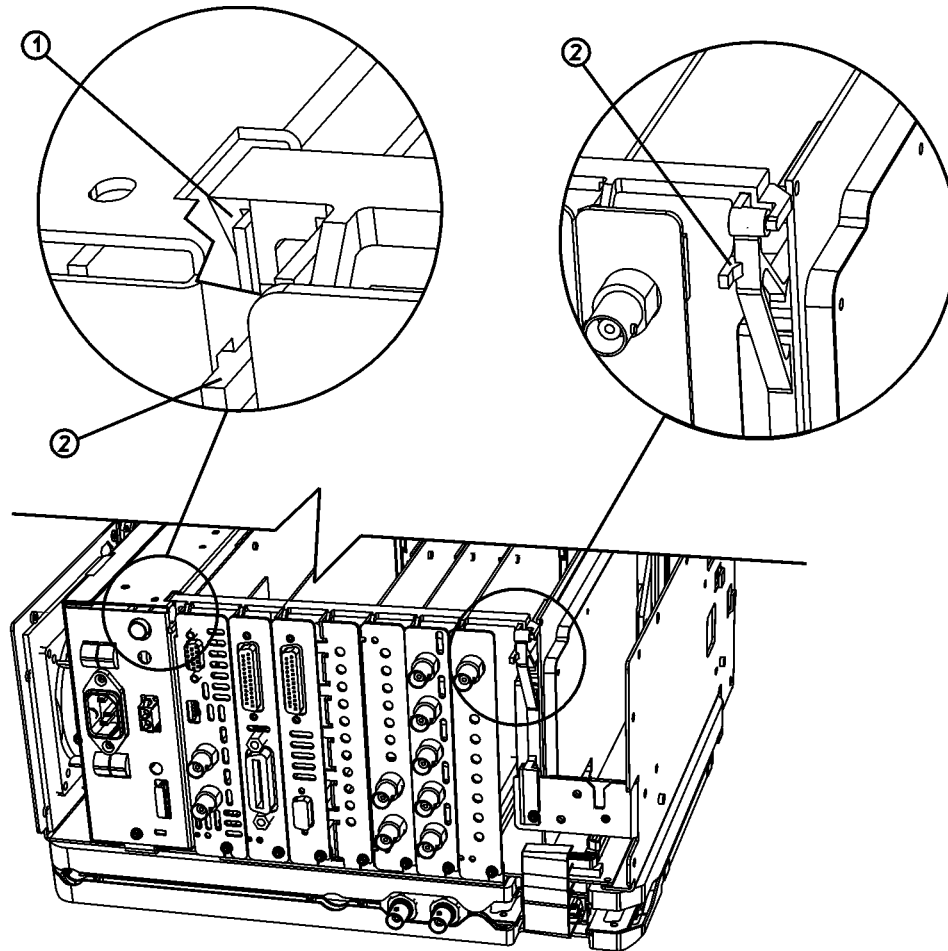

sl755b

Replace the Instrument Covers

1. Tighten all the screws that were loosened in the removal procedure to 101 N-cm (9 in-lb).
2. See [Figure 2](#). Carefully position the inner shield (1) on the instrument.
3. Replace the screws (2) and (3), and tighten them to 101 N-cm (9 in-lb).
4. Carefully place the spectrum analyzer on the work surface with the front frame facing down.
5. Replace the instrument outer cover aligning the grill on the side of the case to the fan on the A5 power supply assembly.
6. Fit the leading edge of the case completely into the slot on the back of the front frame assembly.
7. Replace the rear frame assembly (6) using the four screws (5) to fasten the rear frame to the instrument. Tighten the screws to 236 N-cm (21 inch-pounds).

Firmware Revision Verification

1. Turn on the analyzer and wait for the power-on alignments to complete. Check that there are no error messages displayed.
2. Press **System, More, Show System**. Make a note of the firmware revision and see if Option B72, Expansion Memory, is listed on the display.
3. If the firmware revision is A.04.00 or later, the firmware does not need to be upgraded and you can skip steps 4 through 6.
4. If your firmware revision is prior to A.04.00, you must upgrade your analyzer firmware before the license key can be activated.
5. If Option B72, Expansion Memory is installed, you should upgrade the instrument firmware to the latest version using one of the following methods:
 - Download the instrument firmware via the world-wide web at http://www.agilent.com/find/esa_firmware. This entire process of upgrading firmware will take approximately 45 minutes.
Note: If you are upgrading an EMC analyzer, look for the link stating “*EMC Firmware*” at this website.
 - Receive the latest firmware upgrade disk set by ordering upgrade Option UE2.
Note: Special instructions in the Agilent ordering configurator should have made you aware of Option UE2 in case access to the internet wasn't available.
6. If Option B72, Expansion Memory is not installed, you should upgrade the instrument firmware to version A.07.05. This is the latest version for instruments that do not have Option B72 installed.
 - Download the instrument firmware via the world-wide web at http://www.agilent.com/find/esa_firmware. Look for the link stating “*ESA Firmware Version A.07.05*”. This entire process of upgrading firmware will take approximately 45 minutes.
 - Order upgrade Option B72, which includes the expansion memory and the latest ESA firmware upgrade disk set.

Activate the Option B7B License Key

The license key supplied in this kit allows you to activate the TV Trigger and Picture-On-Screen Option (Option B7B).

1. Press **System, More, More, Licensing, Option**. When you press **Option**, the alpha editor will be activated. For instructions on using the alpha editor, refer to the *Agilent Technologies ESA Spectrum Analyzers User's Guide*.
2. Use the alpha editor to enter the three-character designation for the option, in this case, "B7B", that you want to activate.
3. Press **Enter** when done.
4. Press **License Key**. When you press **License Key** the alpha editor will be activated.
5. Use the alpha editor and the numeric keypad to enter the 12-character license key number (for example: D7C374DABD5B) for the option that you want to activate.
6. Press **Enter** when done.
7. Press **Activate** to turn on the option.
8. If the option and license key entries were correct, a message stating "Option Activated" will appear on the analyzer display.

Functional Testing

1. Turn on the spectrum analyzer and press **System, More, Show System**. Confirm that Option B7B appears in the list of installed options.
2. Connect a source which contains suitable TV carrier signals (for example, terrestrial broadcast or CATV signals).
3. Press **System, Alignments, Auto Align, Off** to disable the background alignment process while viewing TV waveforms and TV pictures. This is necessary to prevent the background alignment process from interrupting the signal paths of the analyzer during the sweep retrace period so as to maintain a constant, uninterrupted video waveform.

NOTE After viewing the TV waveform or picture, re-enable the background alignment process by pressing **System, Alignments, Auto Align, All**. If the background alignment has been disabled for more than 60 minutes or the ambient temperature has changed more than 3 °C, press **System, Alignments, Align Now, All** to ensure measurement accuracy. See the Specifications and Characteristics Chapter for your analyzer model in the *Agilent Technologies ESA Spectrum Analyzers Specifications Guide*, for information about calibration requirements.

4. Set the center frequency of the analyzer to match the TV video carrier frequency by pressing **FREQUENCY**, then entering the desired value and units.
5. Set the span to 20 MHz by pressing **SPAN, 20 MHz**.
6. Press **Auto Couple**.
7. Adjust the reference level of the analyzer to the peak video carrier level by pressing **AMPLITUDE** and using the knob or step keys.

NOTE If the signal is weak and accompanied by excessive noise, you may choose to enable the internal preamp, if installed, to improve the signal-to-noise ratio. Press **AMPLITUDE, More 1 of 2, Int Preamp (On)**.

8. View the spectrum. There should be a strong, “noise-like” video carrier at the center frequency, a weaker, “noise-like” chrominance sub-carrier located 3.58 MHz (NTSC standard) or 4.3 to 4.4 MHz (PAL or SECAM standards) above the video carrier, and a tightly-grouped sound carrier located 4.5 to 6.5 MHz above the video carrier. If you are viewing broadcast or cable TV signals, the lower adjacent channel sound carrier may be very close to the video carrier at the center frequency.
9. Press **BW/Avg, Resolution BW, 3 MHz** to change the resolution bandwidth of the analyzer to 3 MHz. If the test signal does not have adjacent channels present, change the resolution bandwidth to 5 MHz. However, if strong adjacent channel signals are present (primarily the sound carrier of the lower adjacent channel), set the resolution bandwidth and video bandwidth to 1 MHz.
10. Press **AMPLITUDE, Scale Type (Lin)** to set the amplitude scale type of the analyzer to Linear.
11. Press **Det/Demod, Detector, Sample** to set the detector mode of the analyzer to Sample.
12. Set the span to 0 Hz by pressing **SPAN, Zero Span**.
13. Press **AMPLITUDE** and using the knob or arrow keys, adjust the reference level so that the signal peaks are within half of a division of the top of the display.
14. Press **Trig, TV Trig Setup** and set the following in the TV Trig Setup menu: Press **Field, Entire Frame**. Press **Sync (Pos) (Sync (Neg))** if viewing a SECAM broadcast). Press **Standard** and then select the appropriate standard for the video signal. Press **TV Source, SA**.

15. Press **Trig, TV** to enable the TV trigger. The default line number for triggering is 17, but this can be changed to any value from 1 to 525 or from 1 to 625, depending on the selected video standard.
16. A time domain display of the demodulated TV waveform should now be visible; see [Figure 7](#). This figure shows a CATV signal (NTSC standard). The waveform should not vary from sweep to sweep within the first 3/4 divisions. Beyond 3/4 of a division, the waveform will vary with the program material.

Figure 7. Demodulated RF Waveform (NTSC; PAL is Similar)

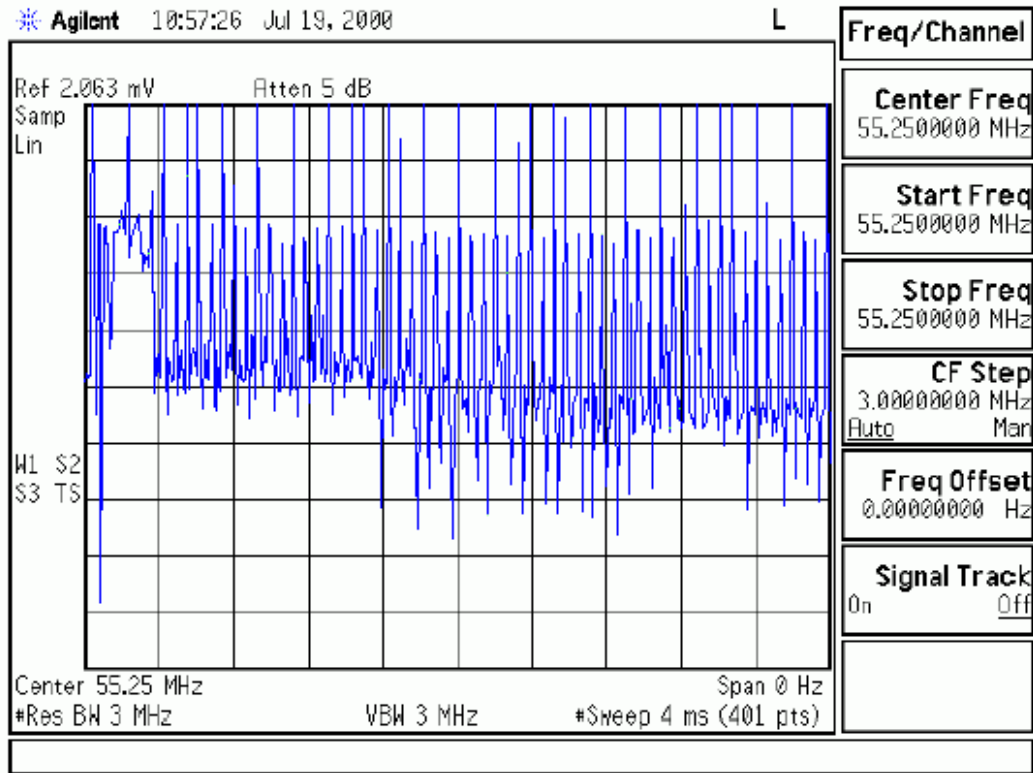

Viewing the TV Picture

17. Press **Sweep, Sweep Time, 100 s** to set the sweep time to 100 seconds. The long sweep time is necessary to minimize disruption of the analog signal path during instrument retrace, which optimizes picture quality.
18. Press **Trig, TV Trig Setup, TV Monitor**.

The display will appear as black-and-white, even if the actual transmission is in color. This is so because the chrominance sub-carrier is ≥ 3.58 MHz above the video carrier, and outside the 3 dB resolution bandwidth of the analyzer.